



SANIERUNG THEATER DER UNIVERSITÄTS- UND HANSESTADT GREIFSWALD

ENTWURFSPLANUNG

17. JANUAR 2022

GRUNDLAGEN



STANDORT



STANDORT

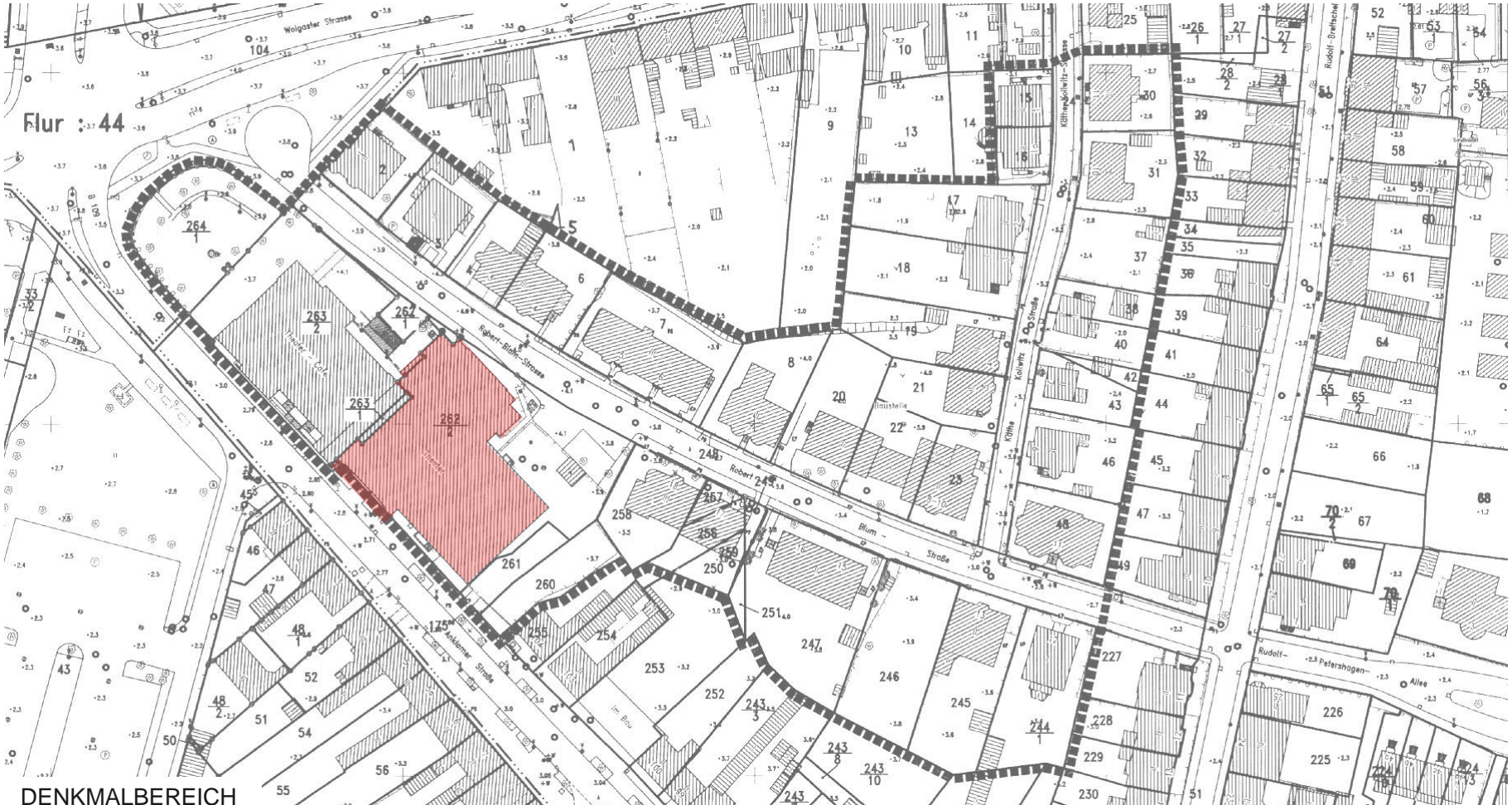

DENKMALBEREICH



HAUPTTEINGANG



ANLIEFERUNG



SICHT ANKLAMER STRASSE



SICHT STADTHALLE

KONZEPT

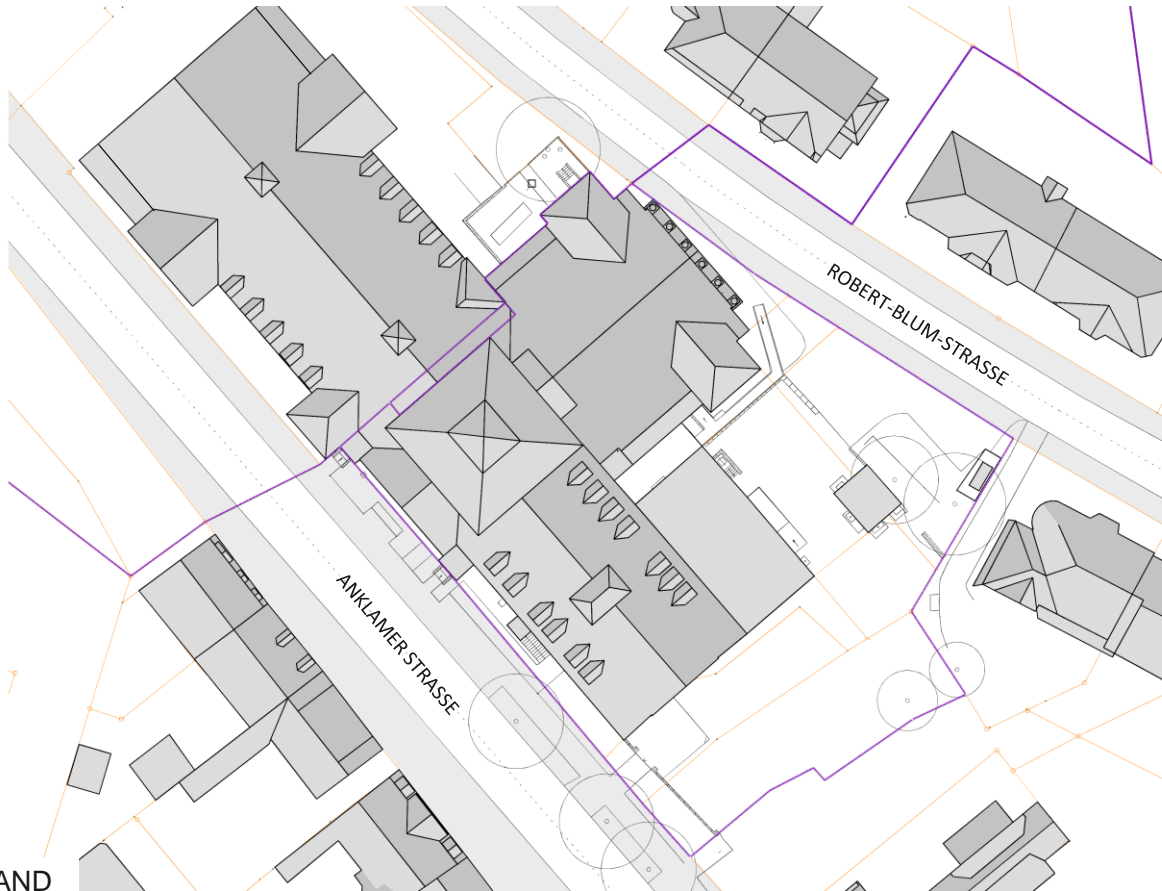

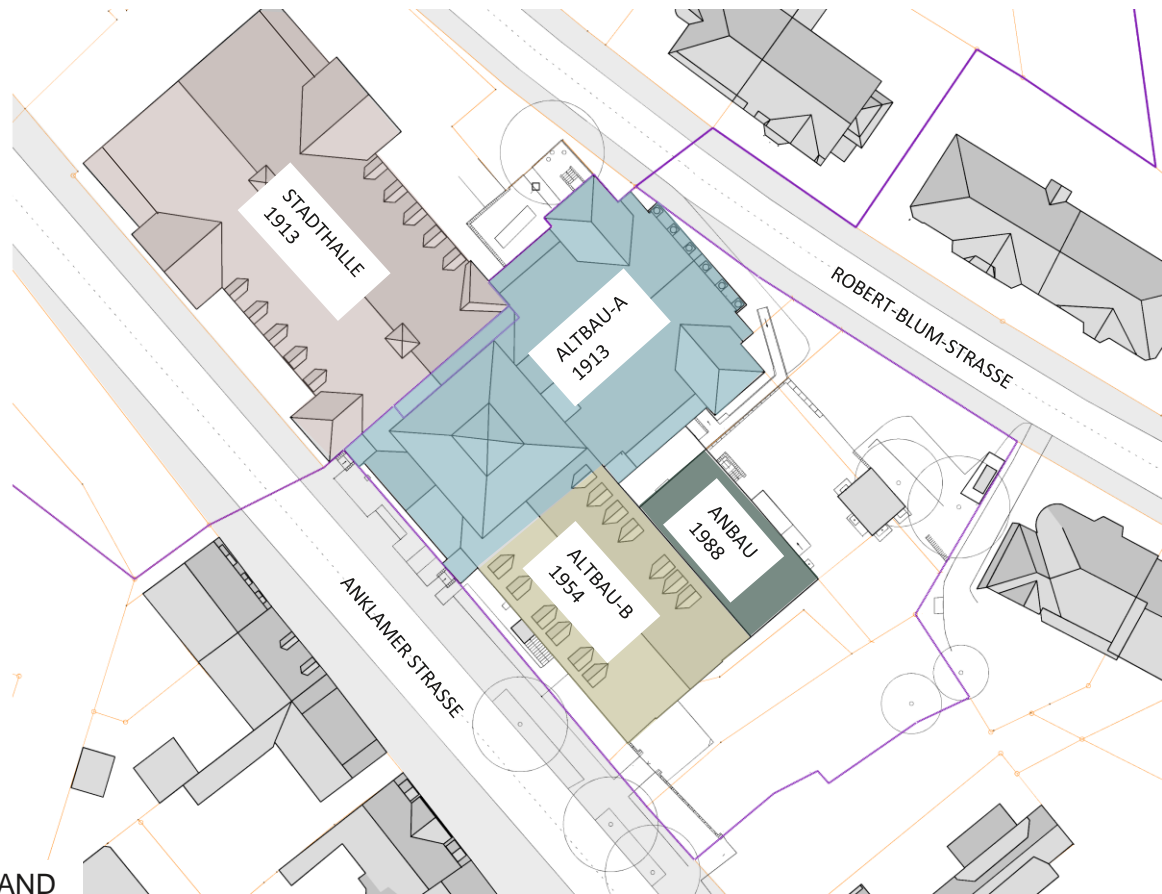

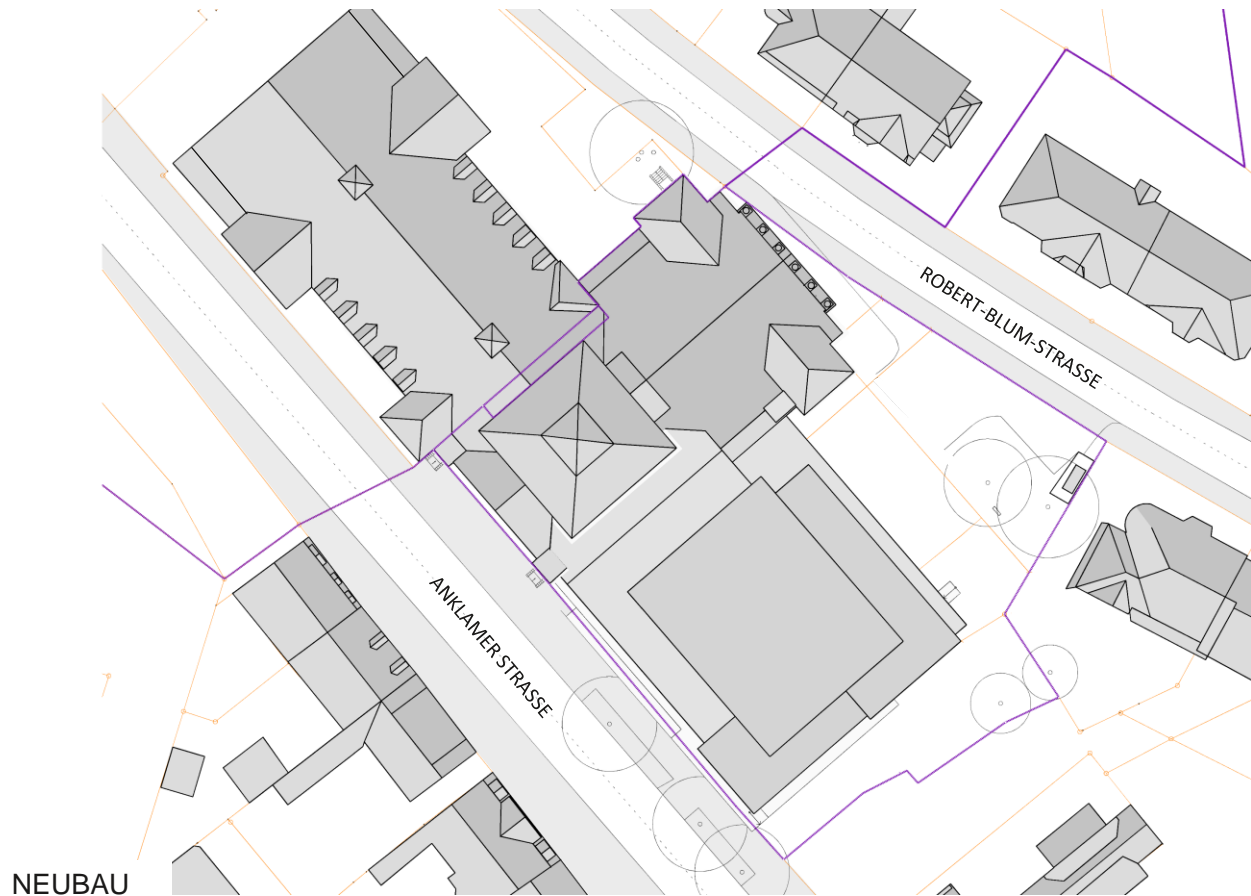

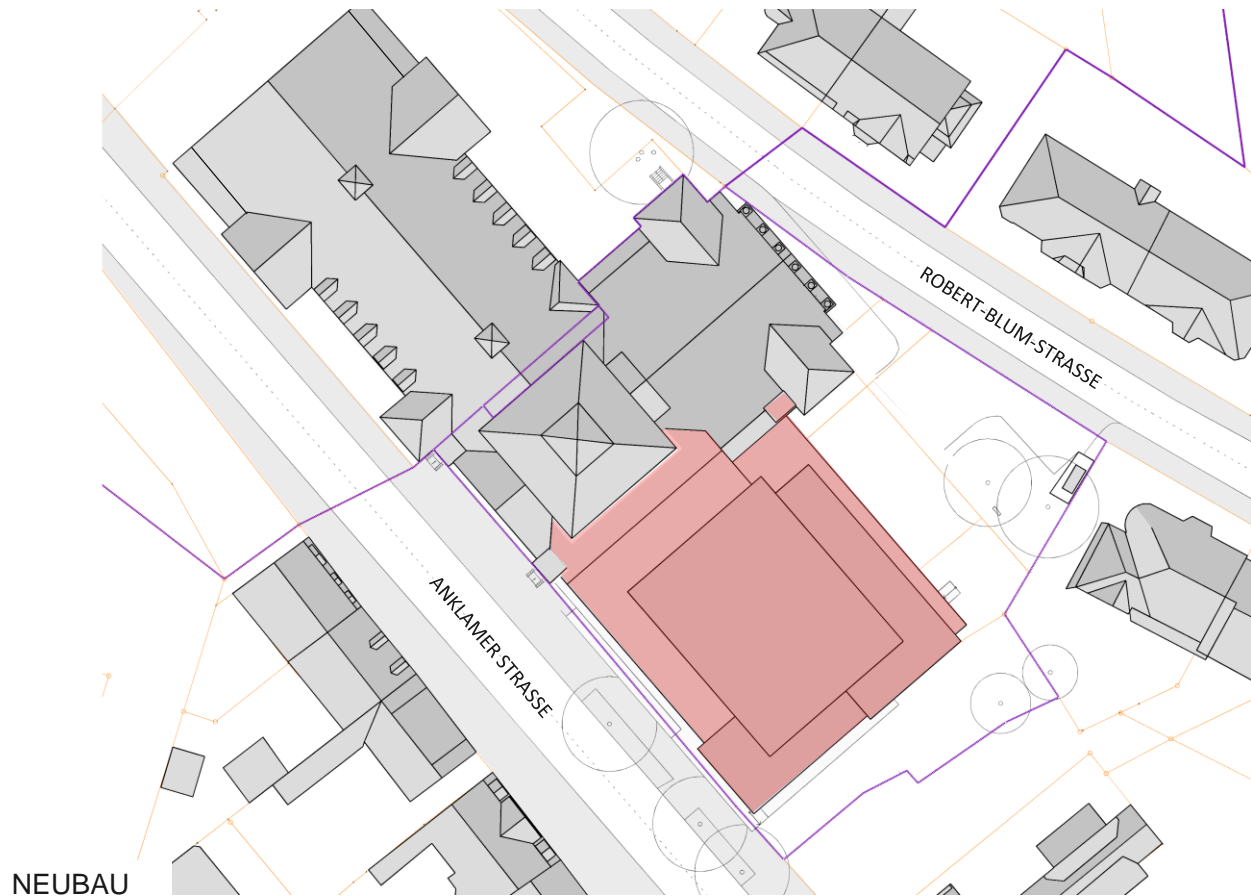

Dietrich | Untertrifaller

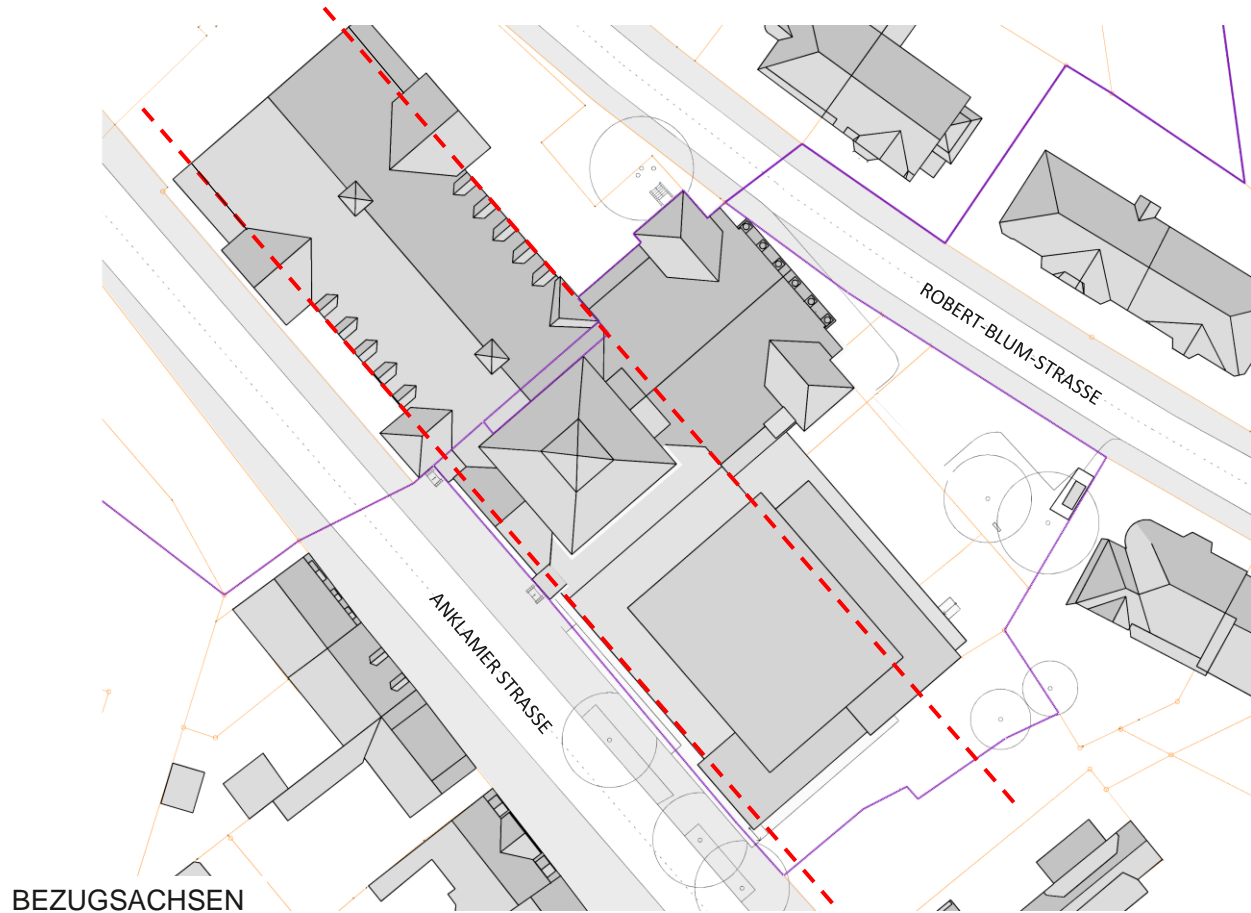

Dietrich | Untertrifaller

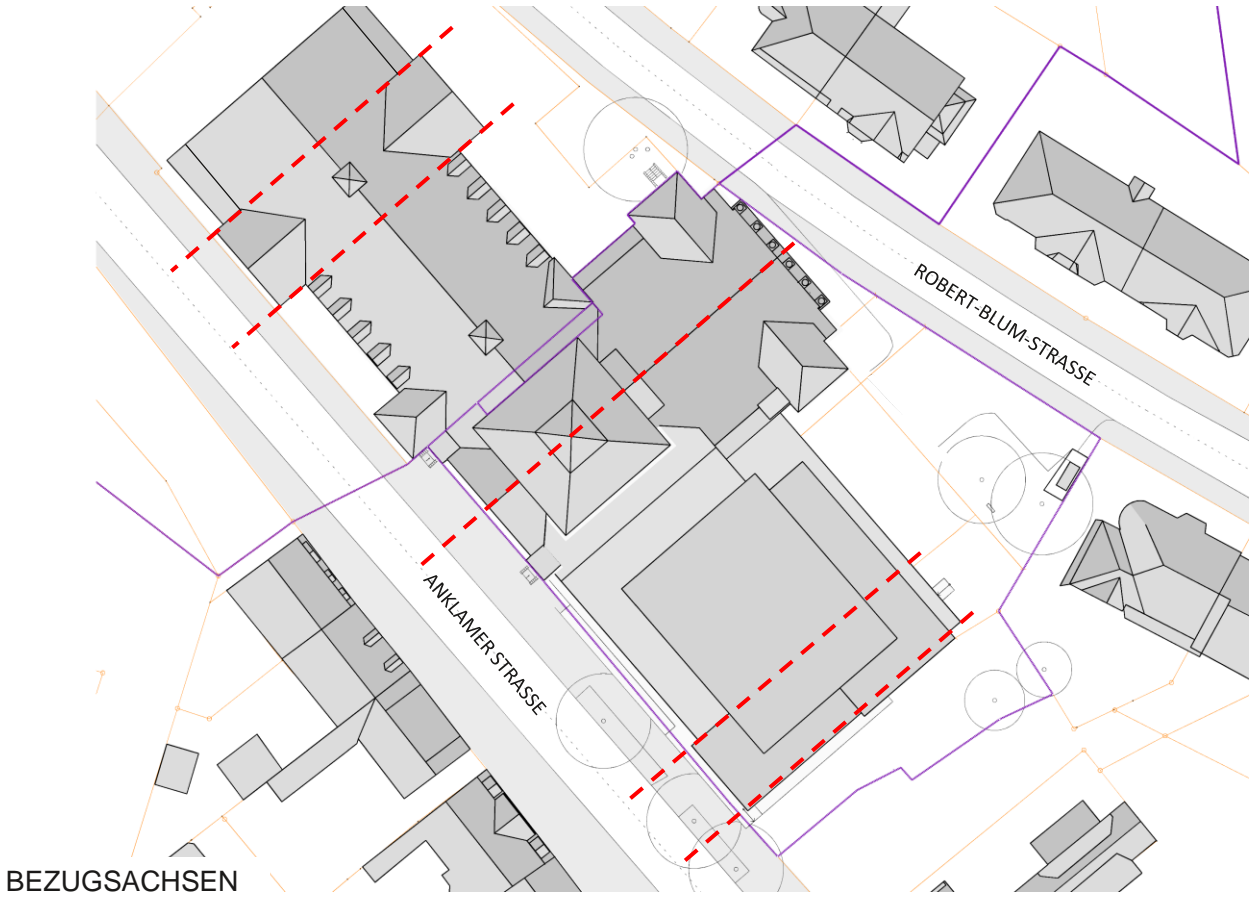

BEZUGSACHSEN

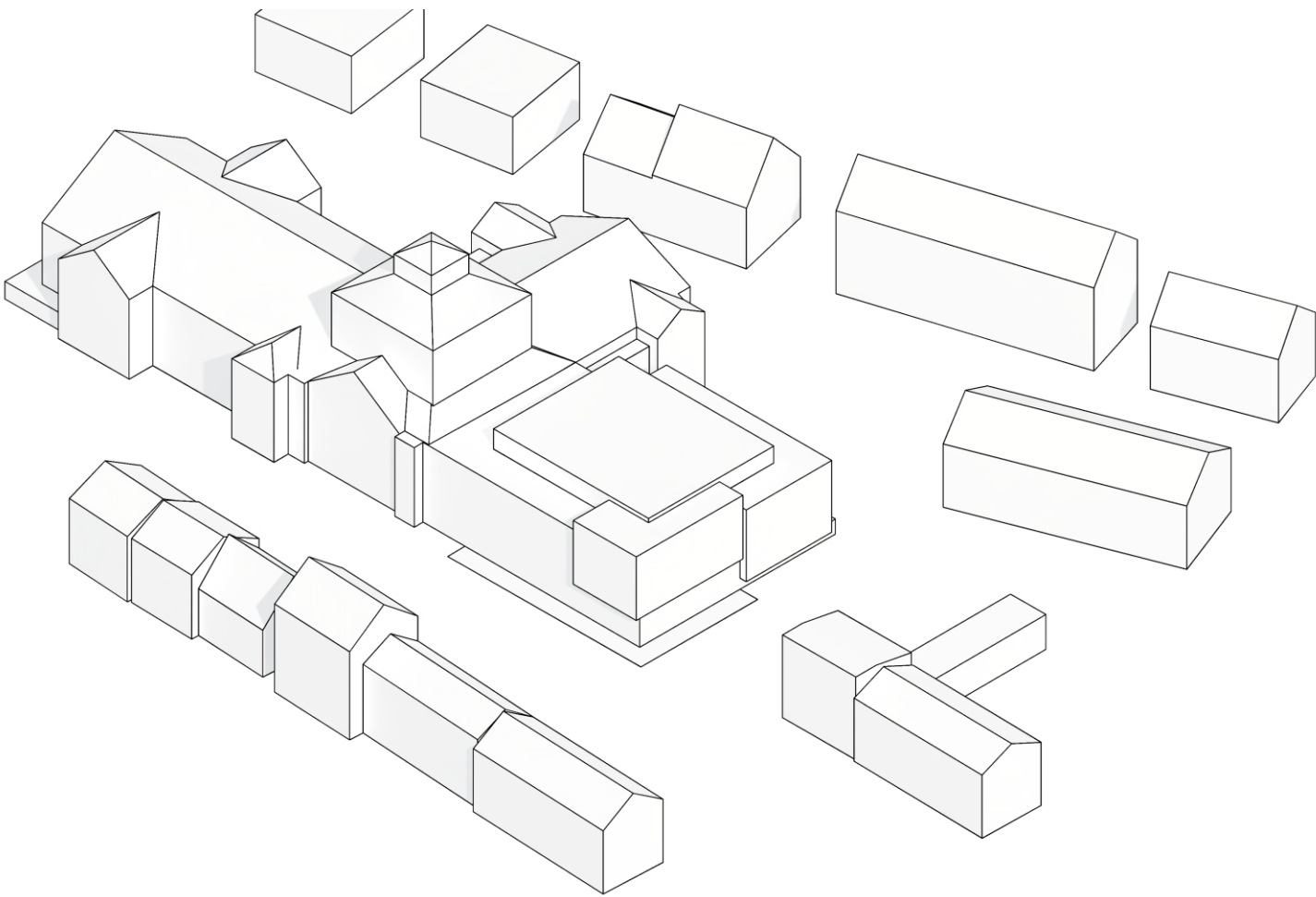

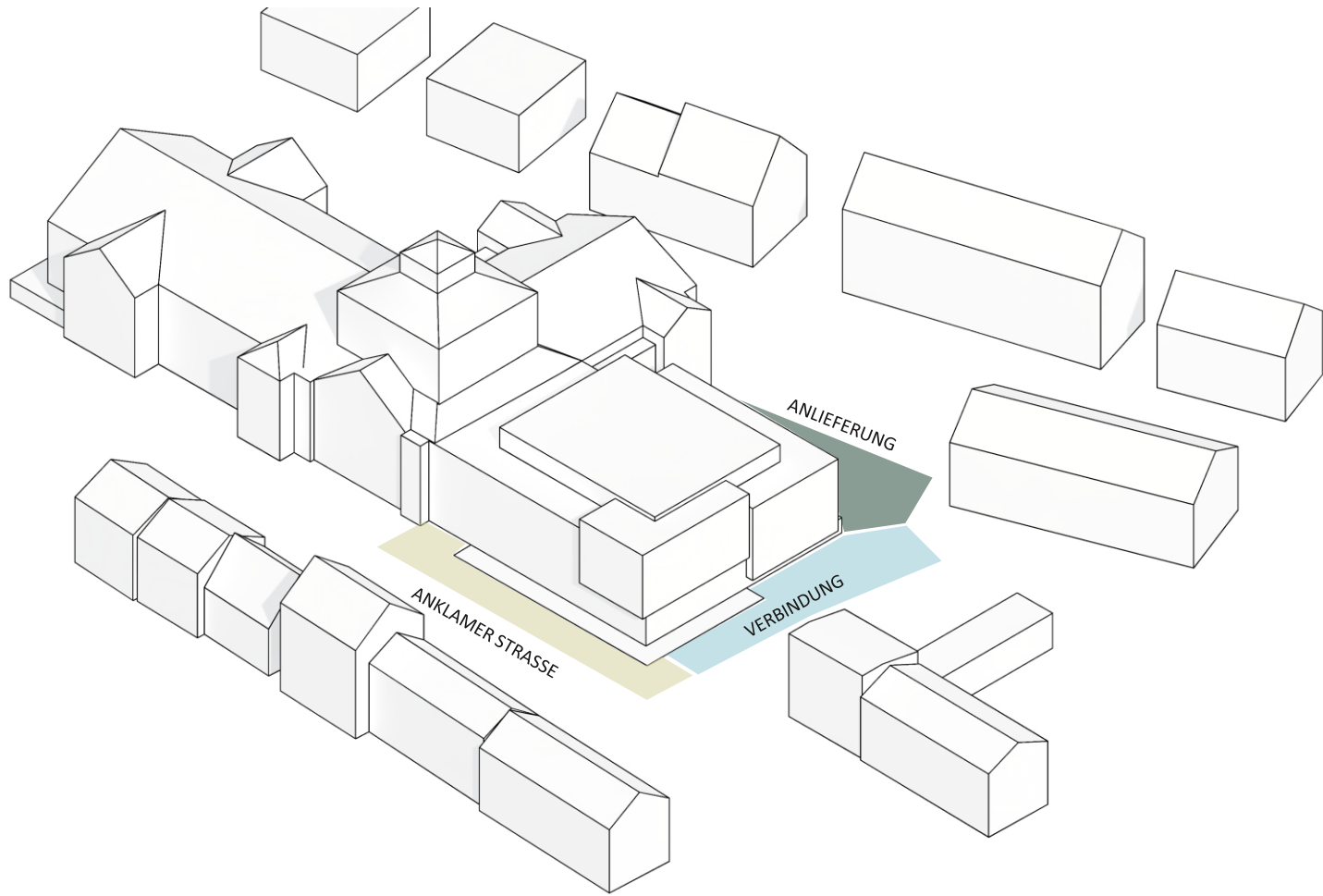

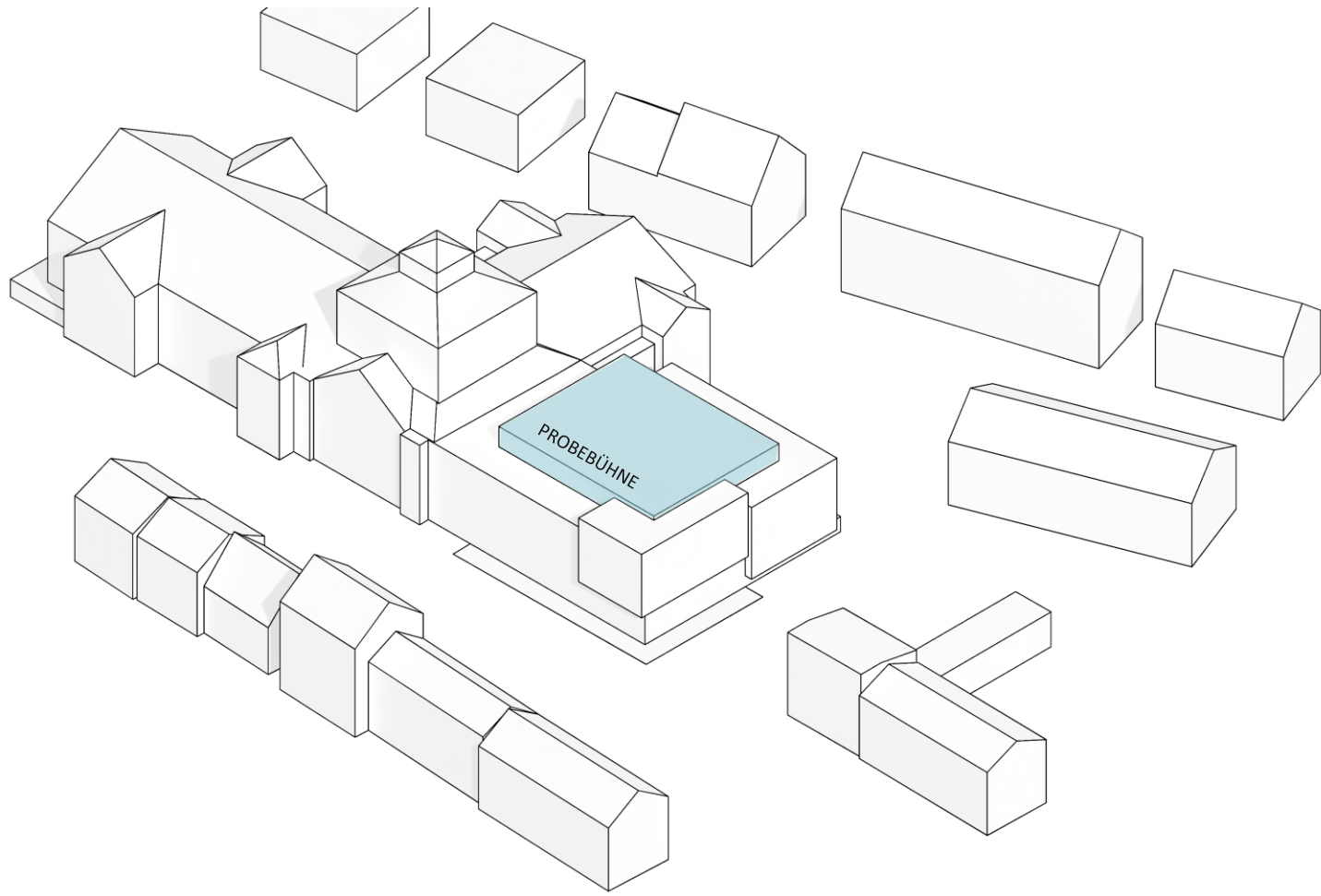

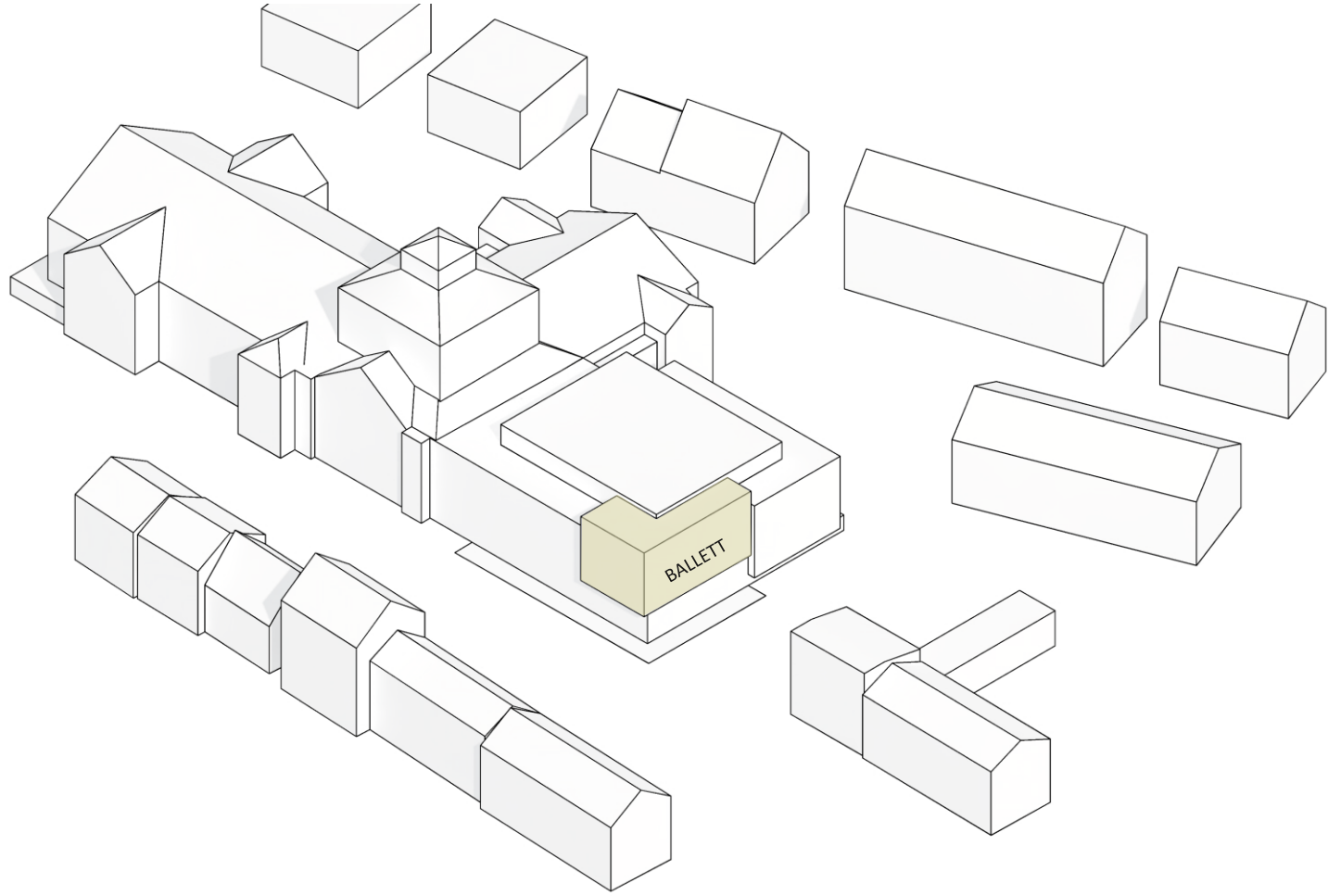

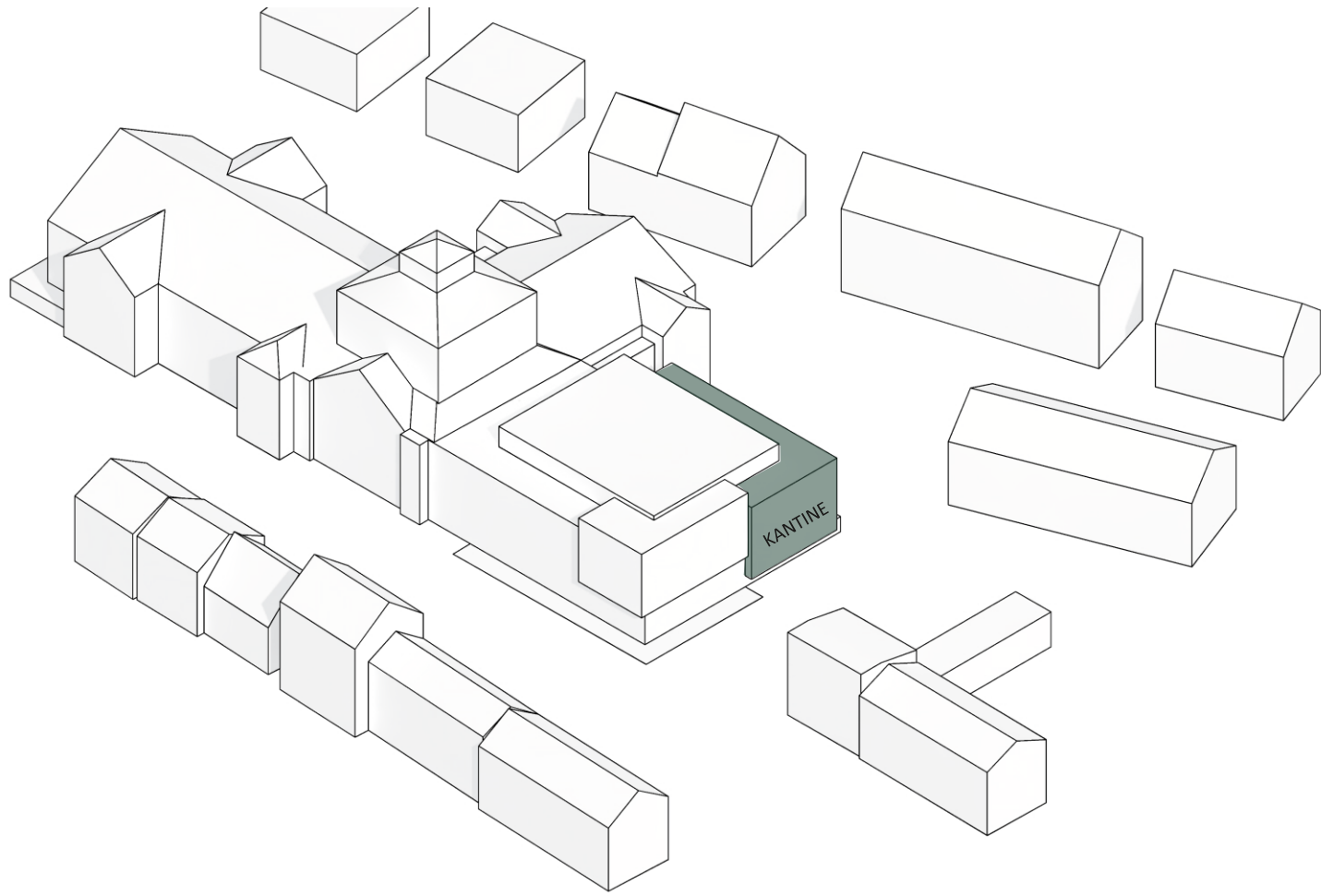

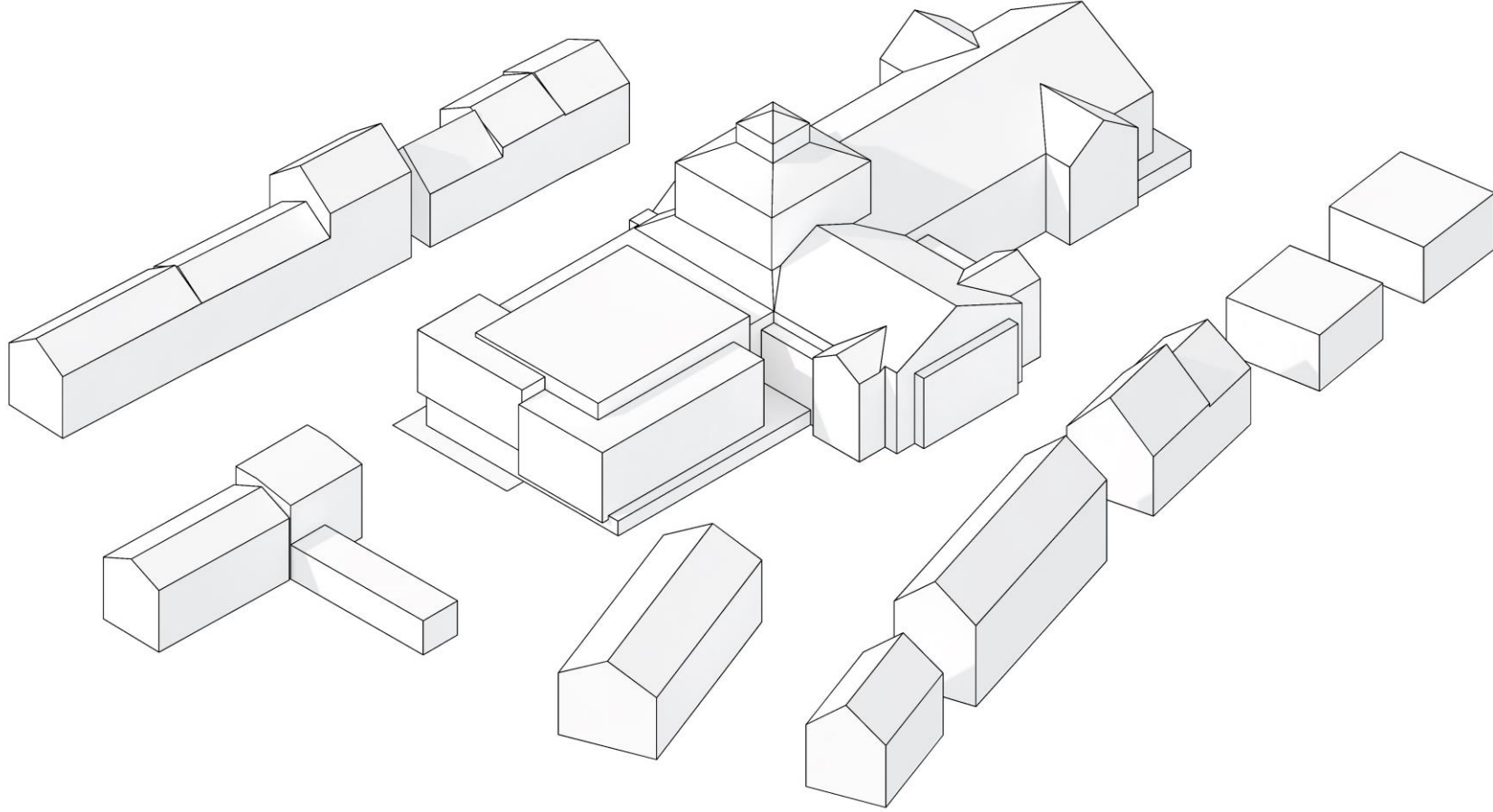

ENTWURFSPLANUNG



LAGEPLAN

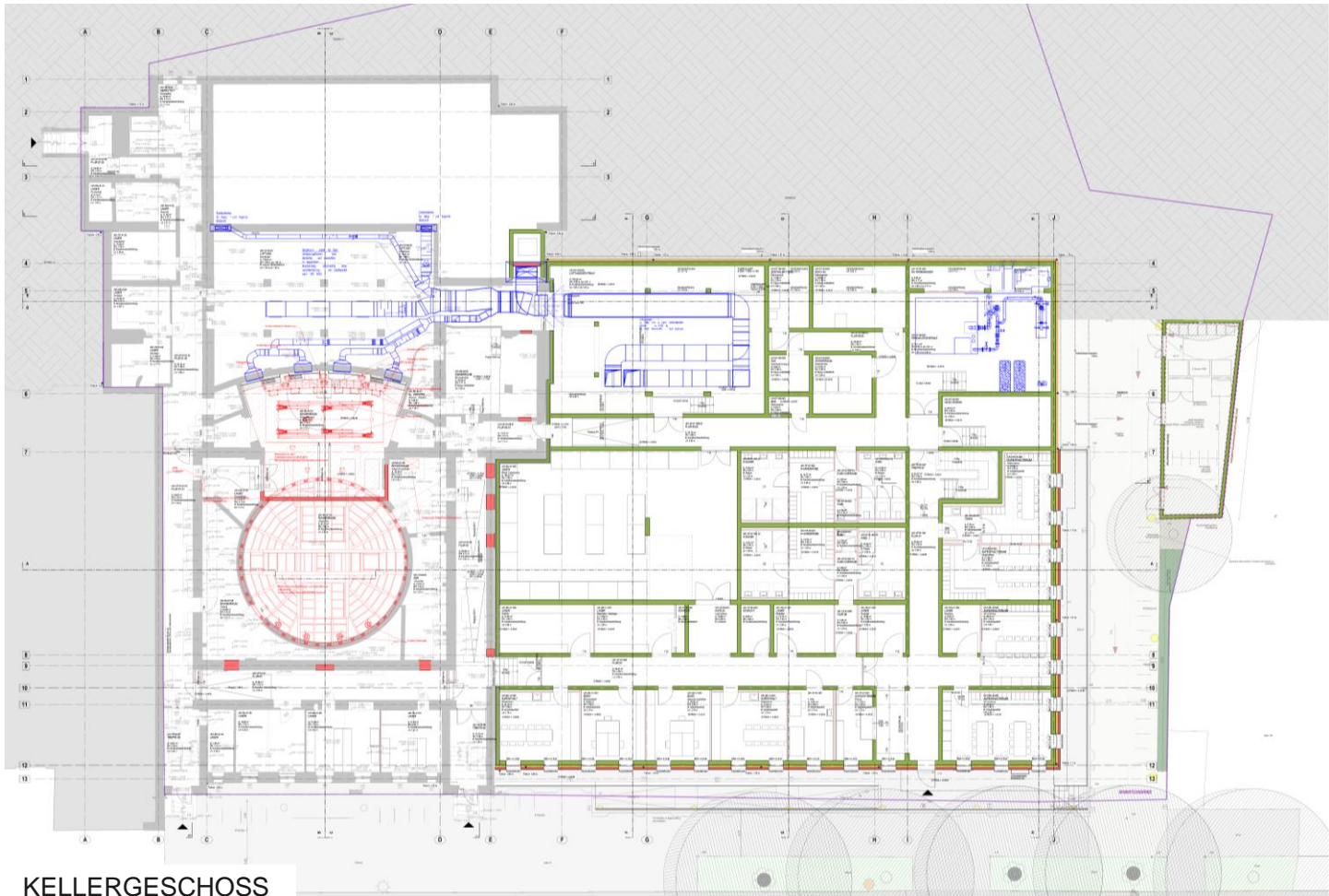

KELLERGESCHOSS

Dietrich | Unterfraller

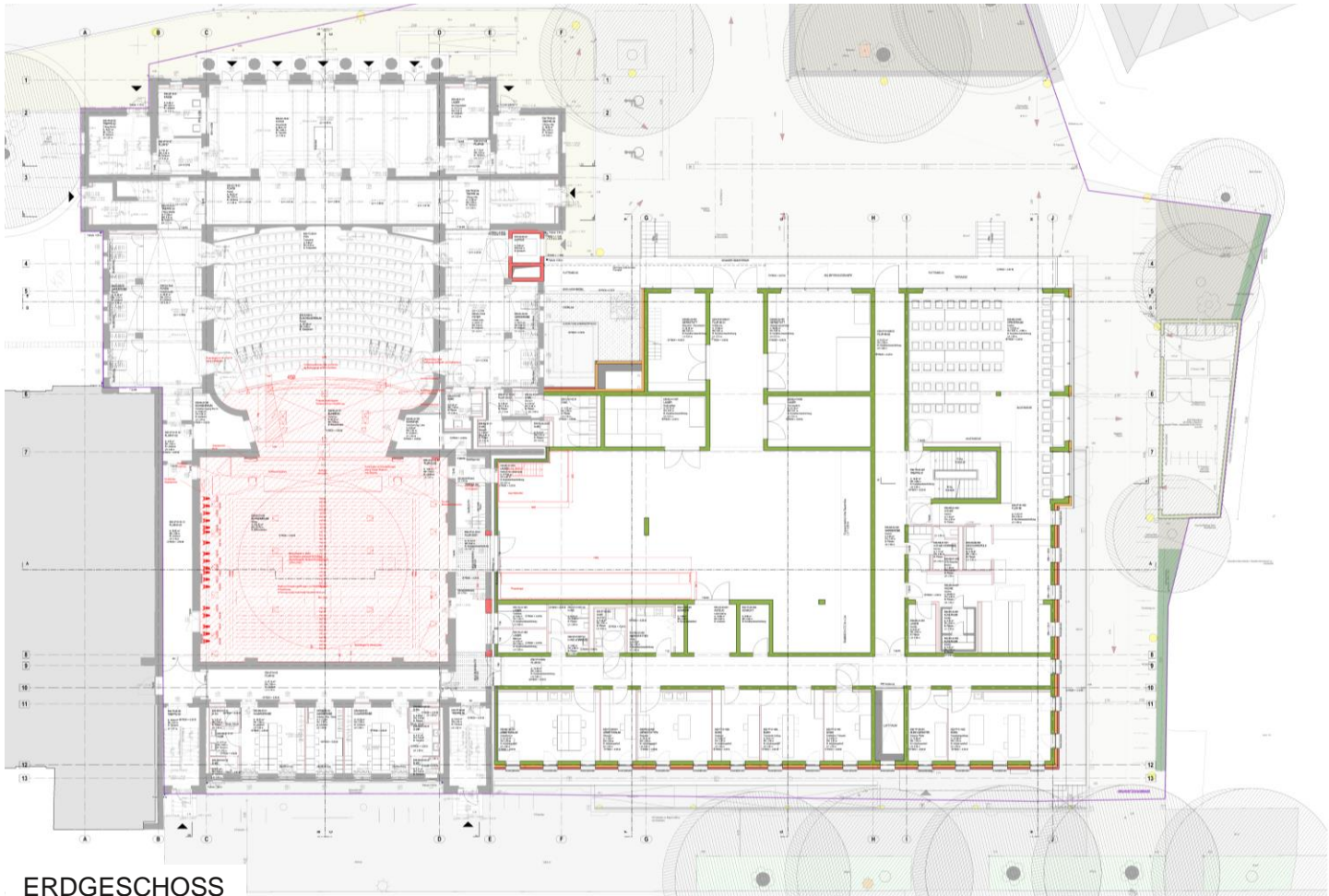

ERDGESCHOSS

Dietrich | Unterfraller

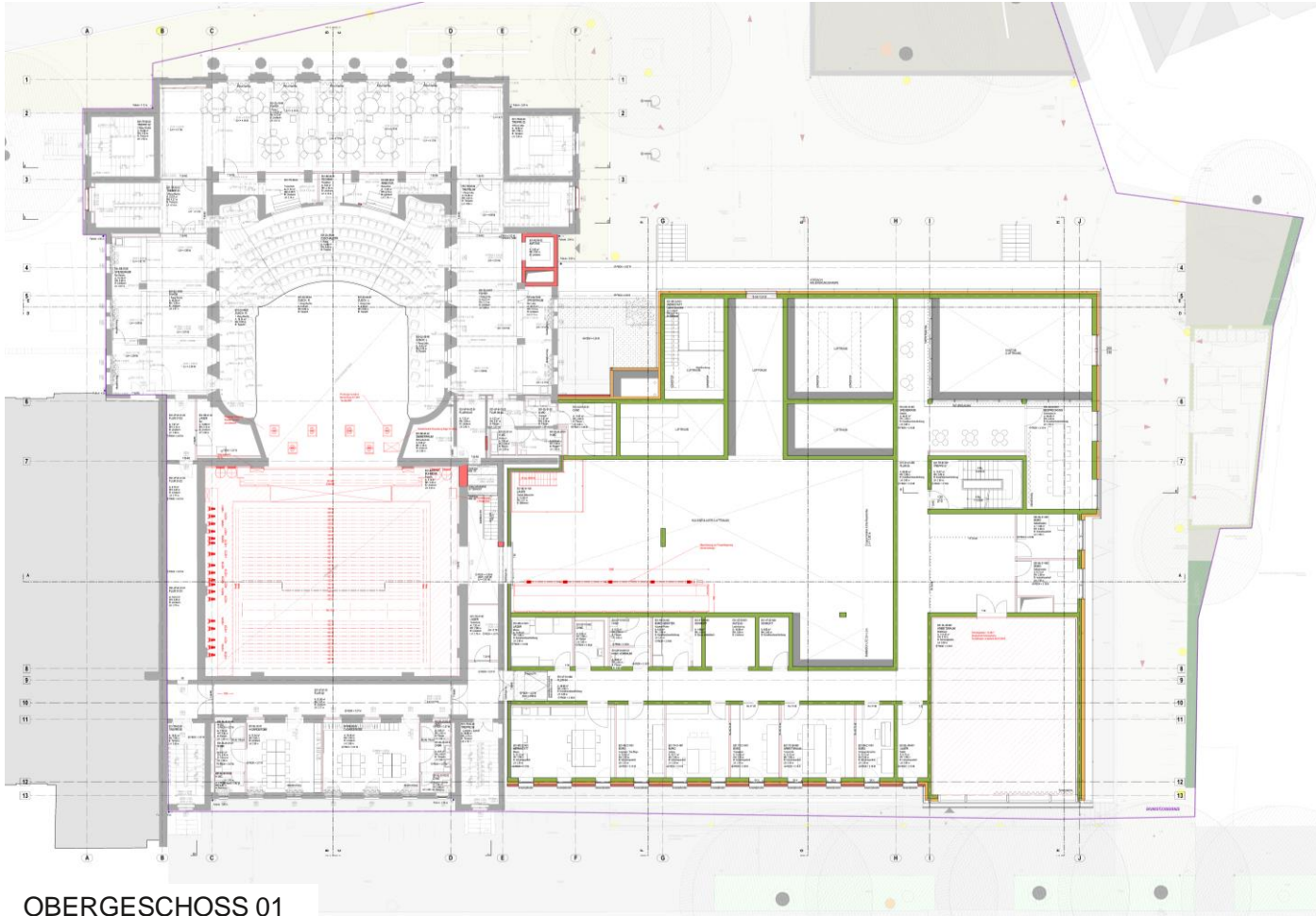

OBERGESCHOSS 01

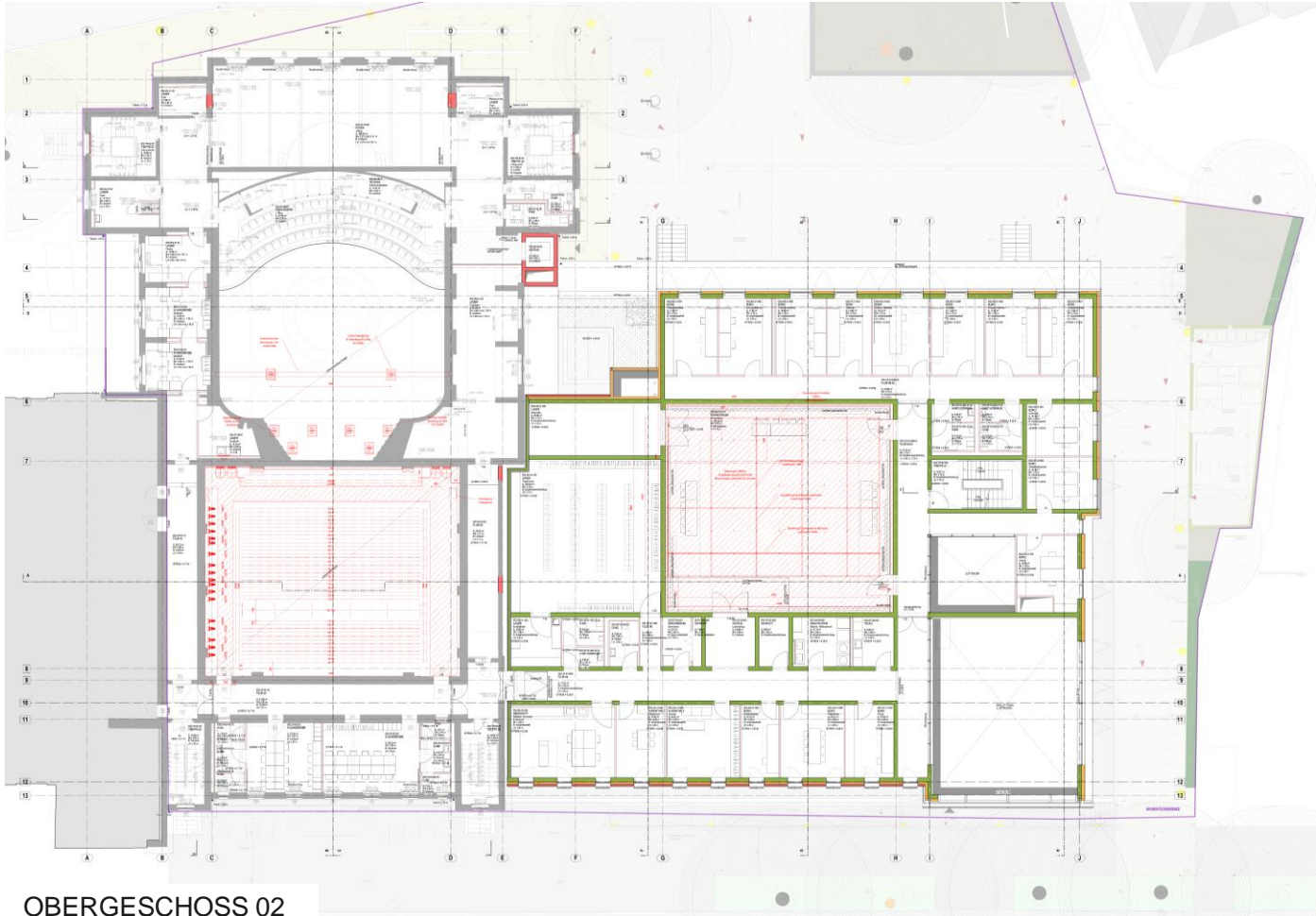

OBERGESCHOSS 02

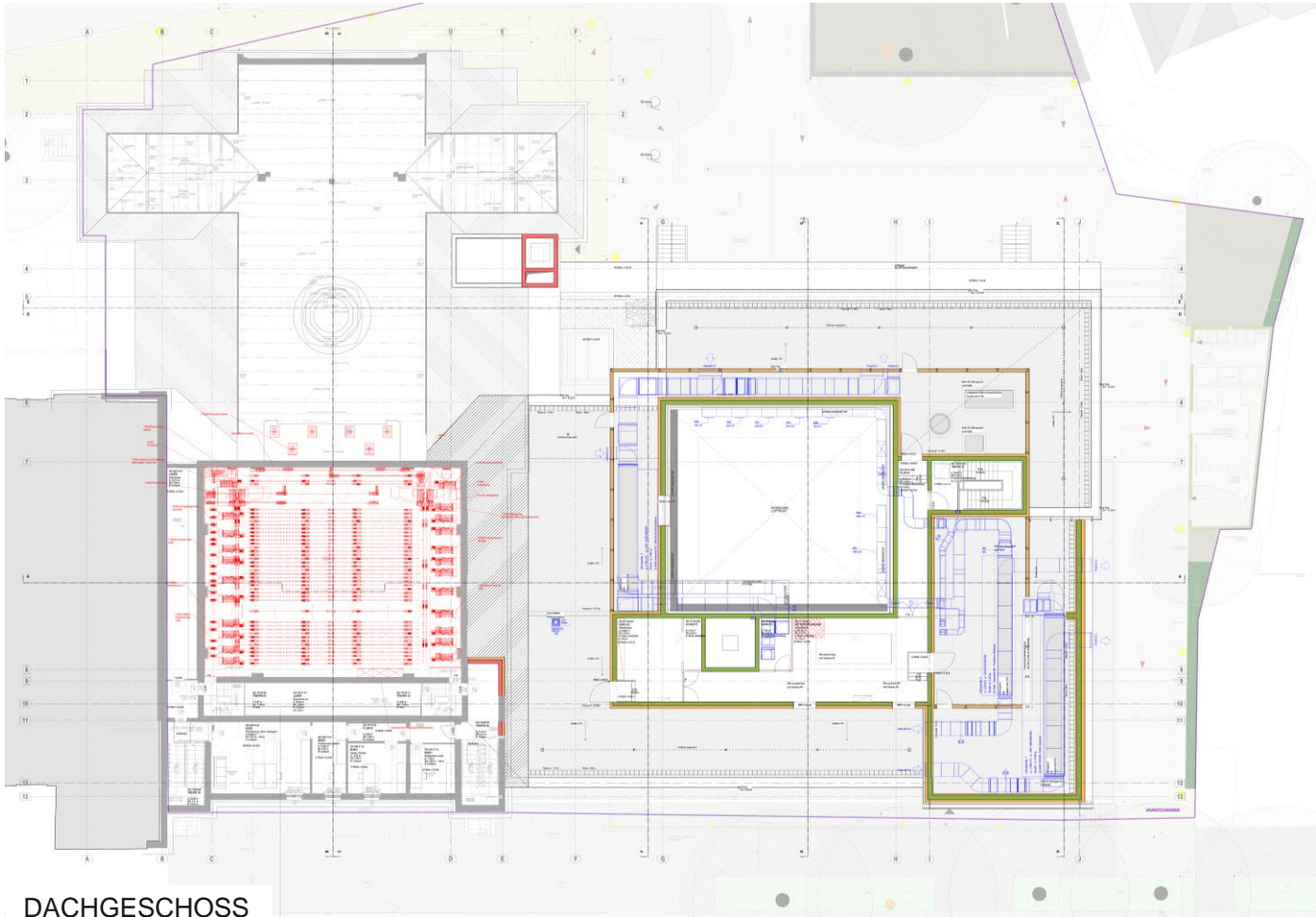

DACHGESCHOSS

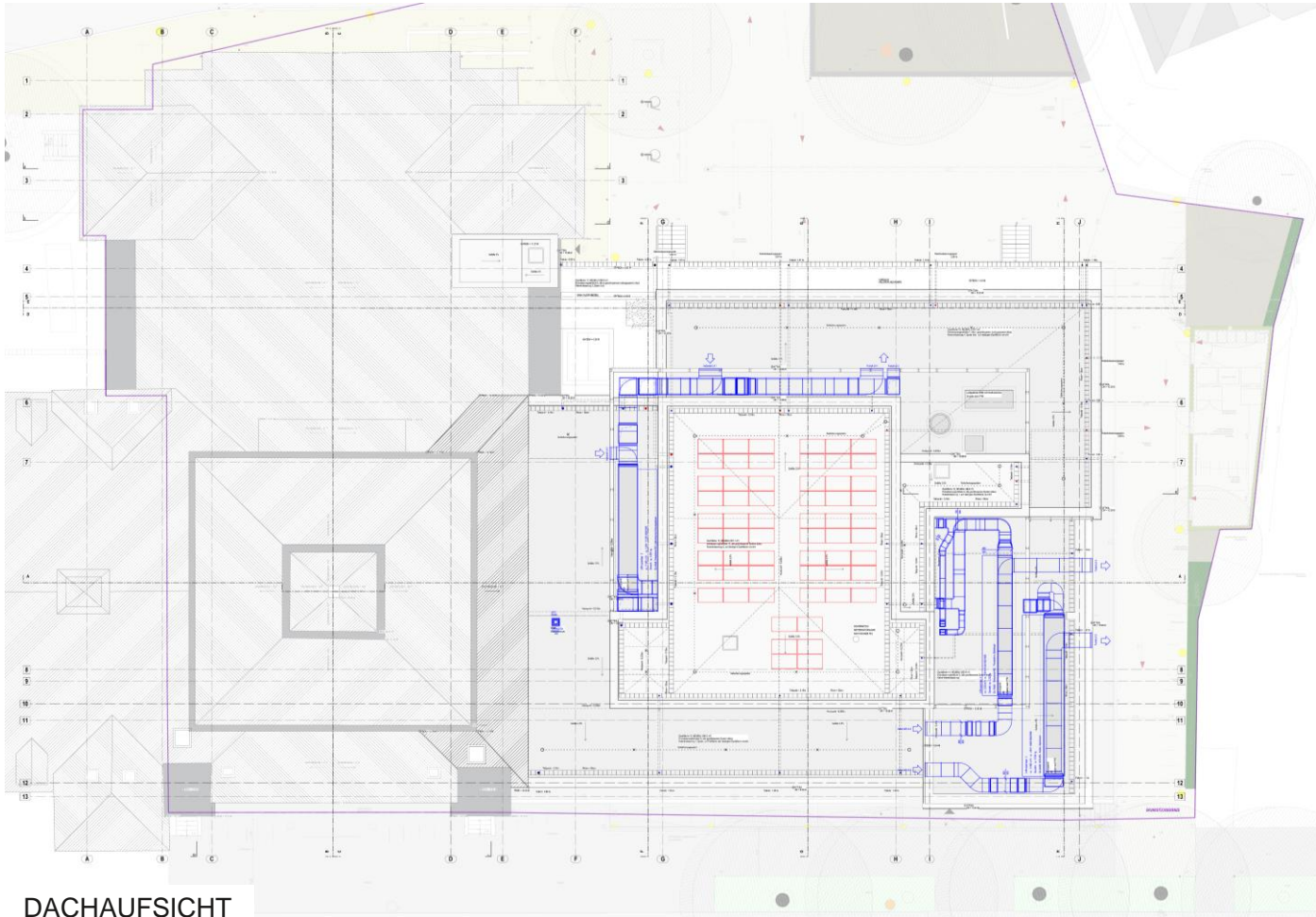

DACHAUFSICHT

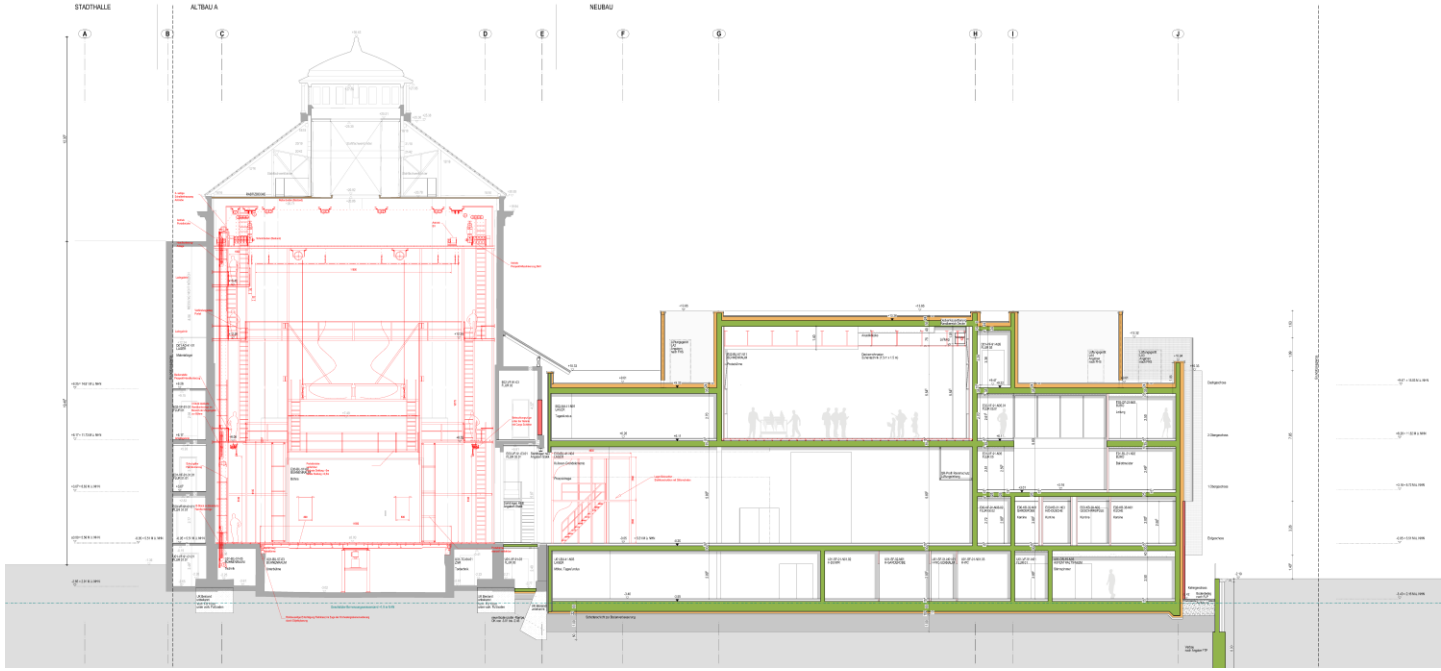

SCHNITT A-A

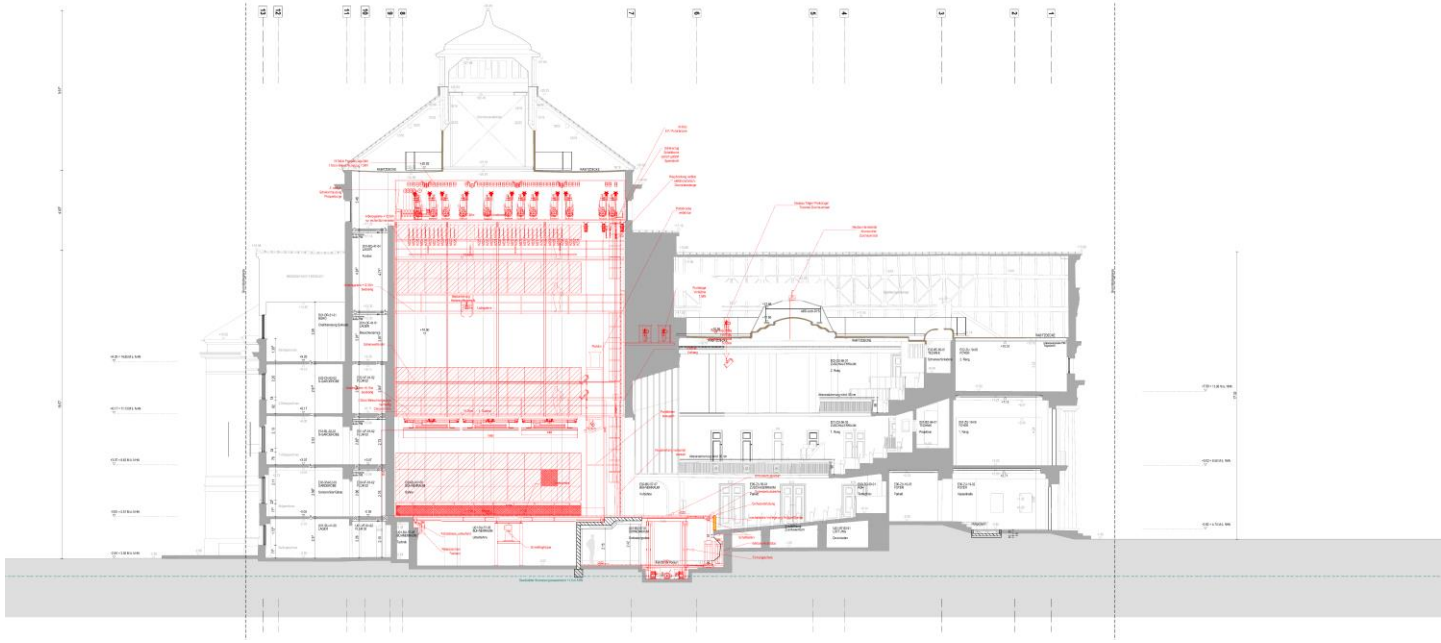

SCHNITT B-B

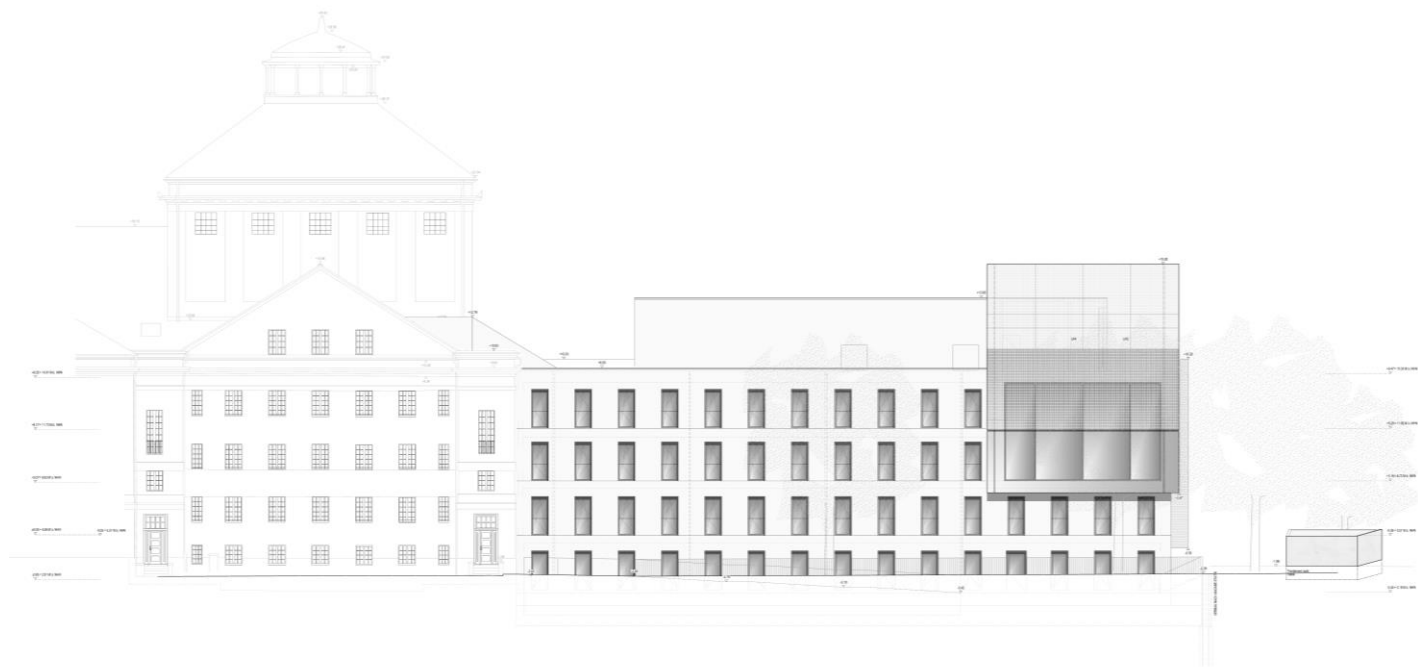

ANSICHT SÜD

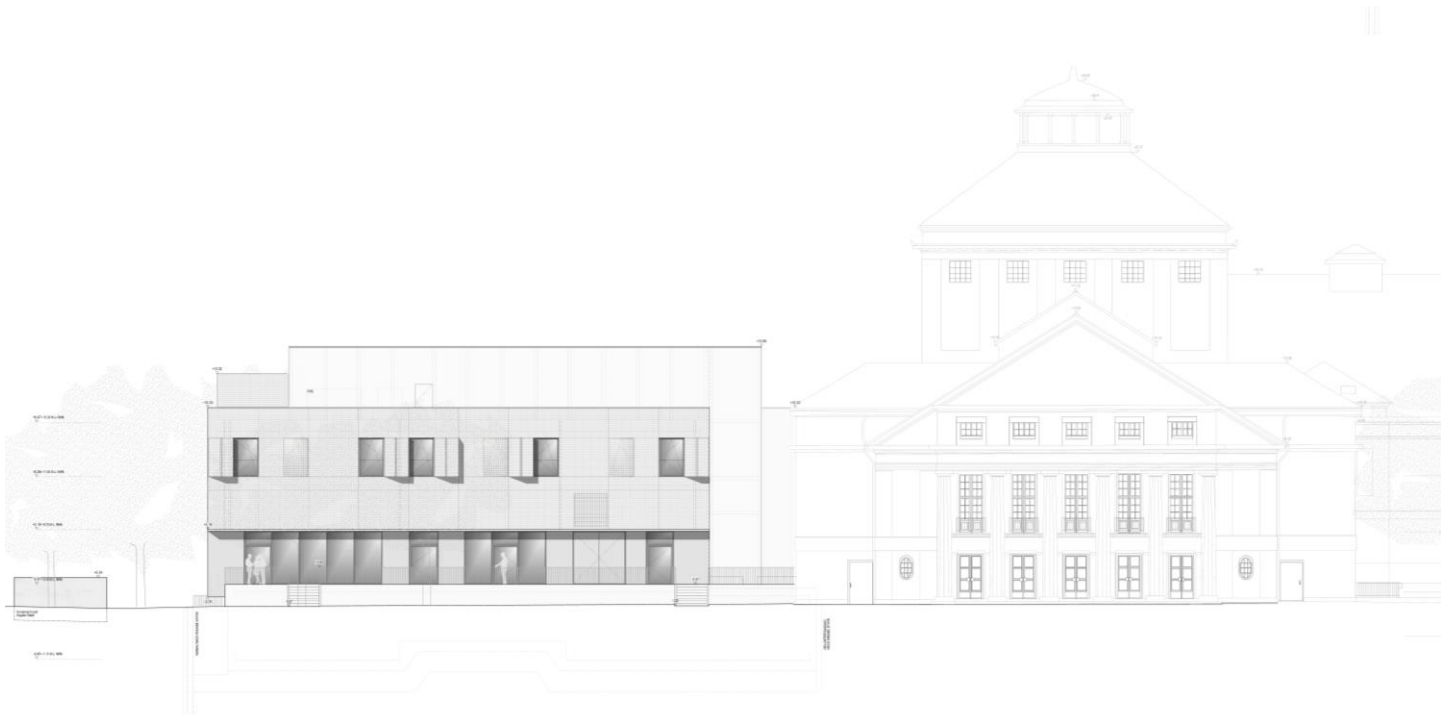

ANSICHT NORD



ANSICHT OST



ANSICHT WEST



VISUALISIERUNG ROBERT-BLUM-STRASSE



VISUALISIERUNG ANKLAMER STRASSE

KOSTEN

Kostengruppe nach DIN 276

KoBe vom 10.12.2021
Summe Brutto
indiziert II/2021

KG 100 Grundstück	1.952 €
KG 200 Herrichten und Erschließen	1.593.858 €
KG 300 Bauwerk-Baukonstruktion	21.481.448 €
KG 400 Bauwerk-Technische Anlagen	16.195.428 €
KG 500 Außenanlagen	992.425 €
KG 600 Ausstattung und Kunstwerke	0 €
KG 700 Baunebenkosten	8.719.723 €
Gesamtsumme aller Kostengruppen	48.984.834 €
Gesamtsumme 300+400	37.676.876 €

KOSTEN

